

8 7 6 5 4 3 2 1

NOTES - UNLESS OTHERWISE SPECIFIED:

1. MATERIAL: BRASS
2. COATING: BRIGHT TIN
3. ALL SALES DRAWING DIMENSIONS FOR REFERENCE ONLY. SEE ABBATRON DRAWING 2040B FOR DETAILED DIMENSIONAL AND TOLERANCE INFORMATION.

REVISIONS				
ZONE	REV	DESCRIPTION	DATE	APPR
	-	INITIAL ENGINEERING RELEASE	05/13/2015	JPH

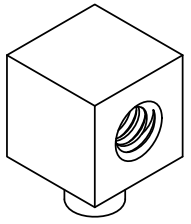
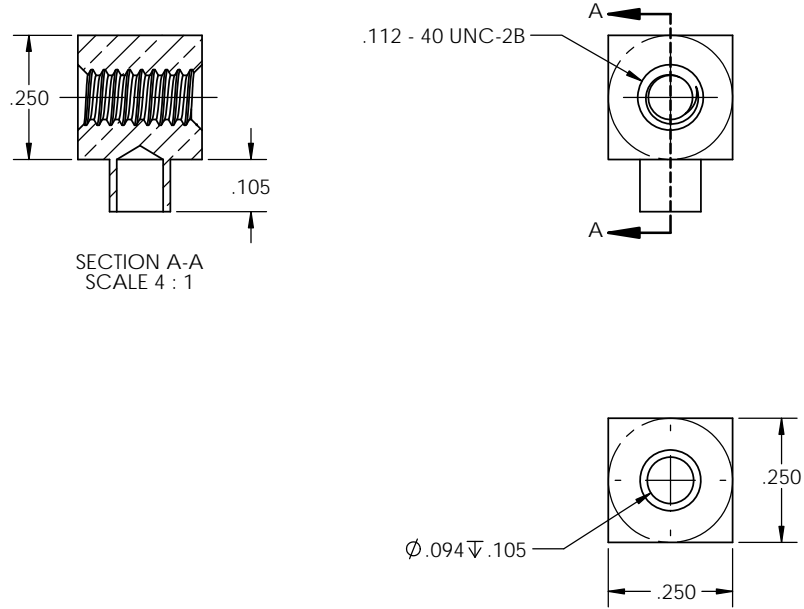

ISOMETRIC VIEW FOR REFERENCE ONLY SCALE NONE

PROPRIETARY AND CONFIDENTIAL
 THE INFORMATION CONTAINED IN THIS DRAWING IS THE SOLE PROPERTY OF ABBATRON. ANY REPRODUCTION IN PART OR AS A WHOLE WITHOUT THE WRITTEN PERMISSION OF ABBATRON IS PROHIBITED.

QTY	FIND NO	CAGE CODE	PART OR IDENTIFYING NUMBER	NOMENCLATURE OR DESCRIPTION	DRAWING OR SPEC NO	NOTES	
PARTS LIST							
				UNLESS OTHERWISE SPECIFIED: DIMENSIONS ARE IN INCHES TOLERANCES: FRACTIONAL ± 1/64 ANGULAR: ±1 TWO PLACE DECIMAL ±.01 THREE PLACE DECIMAL ±.005	NAME	DATE	ABBATRON 13680 S. MOSIERTOWN ROAD 814-724-6440 TEL MEADVILLE, PA 16335 814-333-1912 FAX TITLE: FASTNER, SQUARE, CHASSIS
				INTERPRET GEOMETRIC TOL. PER: ASME Y14.5-2009	JPH	05/13/2015	
				MATERIAL See Notes			
				FINISH 125 Ra, µin			
				APPLICATION			SIZE B DWG. NO. SD2040B REV - SCALE: 3:1 WEIGHT: SHEET 1 OF 1

8 7 6 5 4 3 2 1