

| REVISIONS |             | REVISED BY | DATE | APPR |
|-----------|-------------|------------|------|------|
| SYM       | DESCRIPTION |            |      |      |

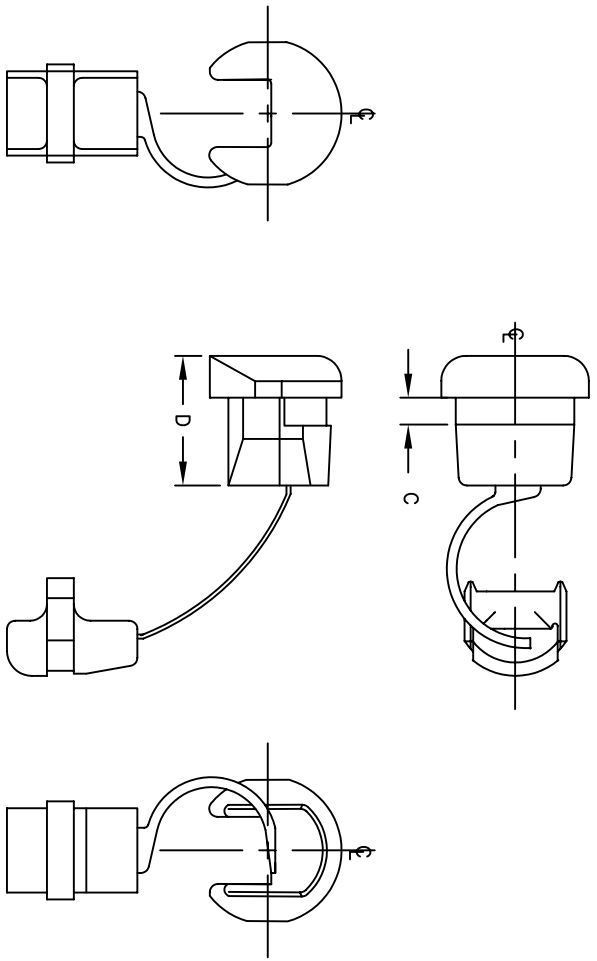

| PART NUMBER | UL/CSA DESCRIPTION | UL TYPE DESIGNATION (USE WITH WIRE TYPES) | CHASSIS DIMENSIONS      |           |                       | BODY LENGTH "D" | TYPE CABLE |
|-------------|--------------------|---|-------------------------|-----------|-----------------------|-----------------|------------|
|             |                    |   | CHASSIS ACROSS HOLE "A" | FLATS "B" | MAXIMUM CHS. THK. "C" |                 |            |
| 938         | SR-3P-4            | SPT-1                                     | 7/16                    | 25/64     | 1/16                  | 13/32           | FLAT       |
| 939         | SR-5N-4            | SV,SVT,HPD                                | 1/2                     | 29/64     | 1/16                  | 7/16            | ROUND *    |
| 823         | SR-6N-4            | SJ,SJT,SJO                                | 5/8                     | 35/64     | 1/16                  | 37/64           | ROUND *    |

NOTE:  
\*ROUND TYPE NOT SHOWN

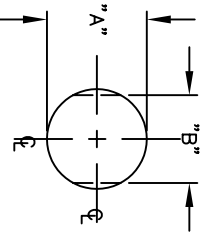

MOUNTING HOLE

SCALE 2:1

|   |                      |  |                               |
|---|----------------------|--|-------------------------------|
| MATERIAL: NYLON TYPE 6/6                          |                      | FINISH: BLACK                              |                               |
| DIMENSIONAL TOLERANCES UNLESS OTHERWISE SPECIFIED |                      | TITLE: 823, 938, 939                       |                               |
| XX  | XXX                  | WIRE STRAIN RELIEF-BUSHING (STRAIGHT THRU) |                               |
| ---   | ---                  | Electronic Connectors and Hardware         |                               |
| FRACTIONS   | ANGLES               | 13680 S. MOSERTOWN RD                      |                               |
| ---   | ---                  | MEADVILLE, PA 16335                        |                               |
| SCALE: 2:1  | DRAWN: Y. SWISHER    | DATE: 2-3-98                               | SIZE: B                       |
| HEAT TREAT: ---                                   | CHECKED: E. MCKINNEY | DATE: 4-13-98                              | DRAWING NUMBER: SD: SMP-00380 |
| PLOT SCALE: 1=1                                   | APPROVED: G. TERRILL | DATE: 4-13-98                              | ISSUE: A                      |