

| BILL OF MATERIALS | | | | |
|-------------------|------|-------------|----------|-------------|
| DET. | QTY. | DESCRIPTION | MATERIAL | FINISH |
| 1 | 1 | SPRING | BE CU | NICKEL |
| 2 | 1 | HEX NUT | STEEL | NICKEL |
| 3 | 1 | LUG | BRASS | ELECTRO TIN |
| 4 | 1 | BODY | BRASS | NICKEL |

FULL SECTION

| REVISIONS | | | | |
|-----------|-------------|------------|------|------|
| SYM | DESCRIPTION | REVISED BY | DATE | APPR |
| | | | | |

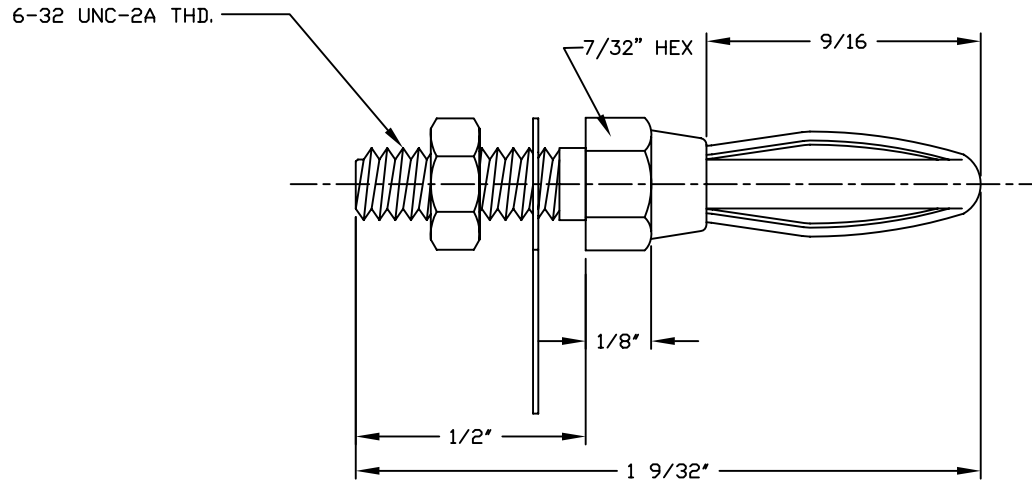
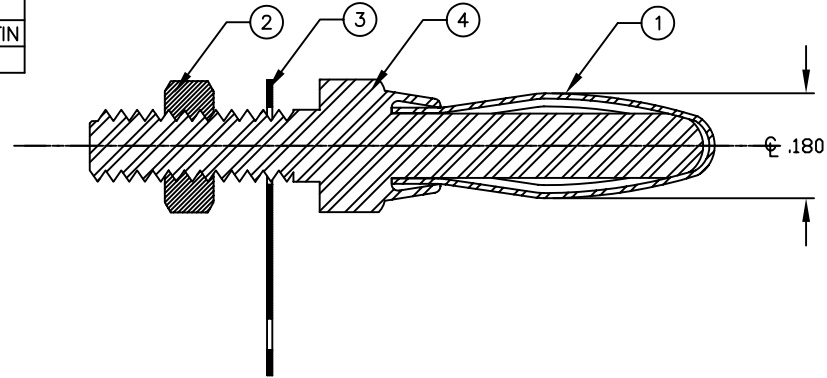

| | | | | | | | | | | |
|--|------|----------------|-----|-----------|--|-----------|--|--|--|---------|
| MATERIAL | | "SEE TABLE" | | FINISH | | SEE TABLE | | ABBATRON Electronic Connectors and Hardware 632 Arch Street, Meadville, Pa. 16335 | | |
| DIMENSIONAL TOLERANCES UNLESS OTHERWISE SPECIFIED | | | | TITLE | | | | | | |
| .XX | .XXX | .XXXX | | | | | | | | |
| ---- | ---- | ---- | | | | | | | | |
| FRACTIONS | | ANGLES | | SCALE | | | | | | |
| ---- | ---- | ---- | 4:1 | | | | | | | |
| HEAT TREAT | | | | DRAWN: | | T. LORD | | DATE | | 3/16/04 |
| PLAT SCALE: | | | | CHECKED: | | T. LORD | | DATE | | 3/16/04 |
| 1:1 | | | | APPROVED: | | T. LORD | | DATE | | 3/16/04 |
| SIZE | | DRAWING NUMBER | | ISSUE | | | | | | |
| B | | SD-103 | | - | | | | | | |