

REVISIONS	
SYM	DESCRIPTION
REVISED	DATE
APPR	

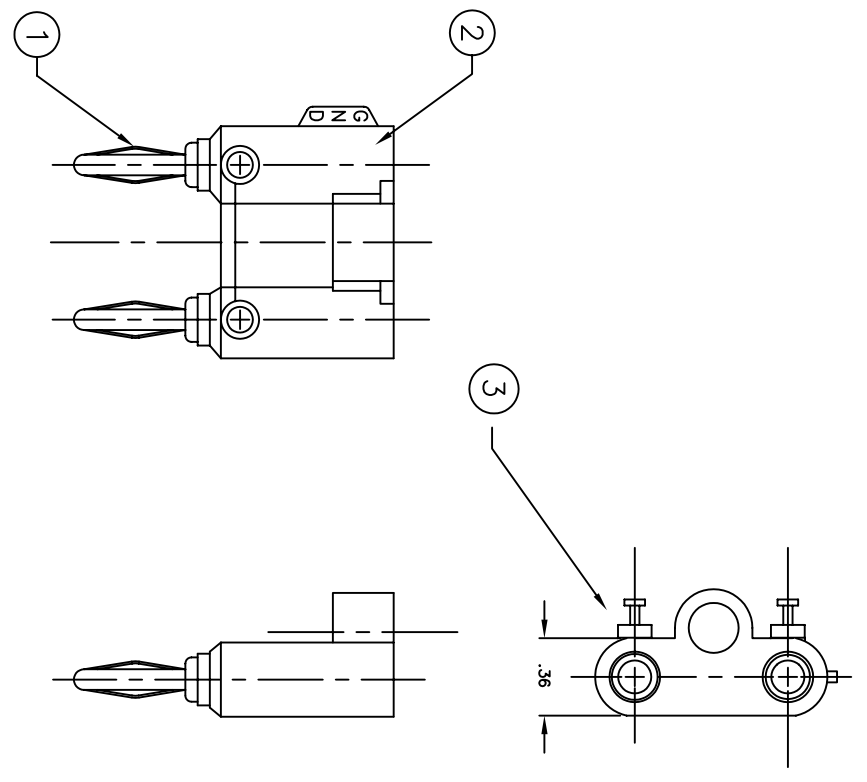

PLUG ASSEMBLY	
PART NO.	COLOR
1676-102	RED
1676-103	BLACK

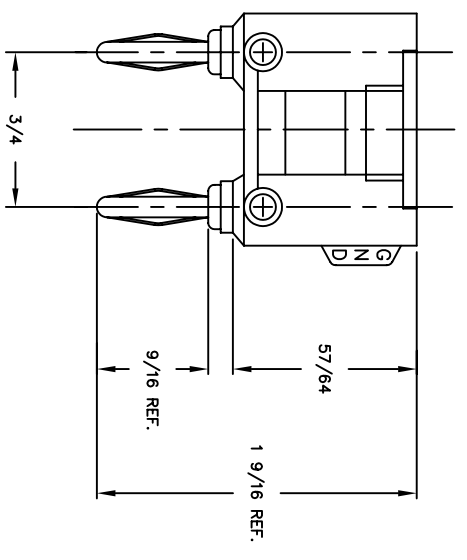

BILL OF MATERIALS			
DET. QTY.	DESCRIPTION	MATERIAL	PLATING
1	BANANA PLUG	"SEE DWG. 1676-30"	NICKEL
2	MOULD COMPOUND	ABS-FR	---
3	TURRET	BRASS	TIN

MATERIAL		FINISH	
"SEE TABLE"		"SEE TABLE"	
DIMENSIONAL TOLERANCES			
UNLESS OTHERWISE SPECIFIED			
.XX	.XX	.XXX	
FRACTIONS	ANGLES	SCALE	
---	---	2:1	
HEAT TREAT			
1=1			
DRAWN E. MCKINNEY		DATE 8-29-95	
CHECKED		DATE	
APPROVED		DATE	
TITLE		SIZE	
1676 SERIES		C SD: 1676	
DUAL BANANA PLUG ASSEMBLY		DRAWING NUMBER	
ABBATRON		ISSUE	
Electronic Connectors and Hardware			
13690 S. MOSERTOWN RD			
MEADVILLE, PA 16335			