

REVISIONS				
SYM	DESCRIPTION	REVISED BY	DATE	APPR

NOTE:

1.) ALL DIMENSIONS APPLY AFTER PLATING

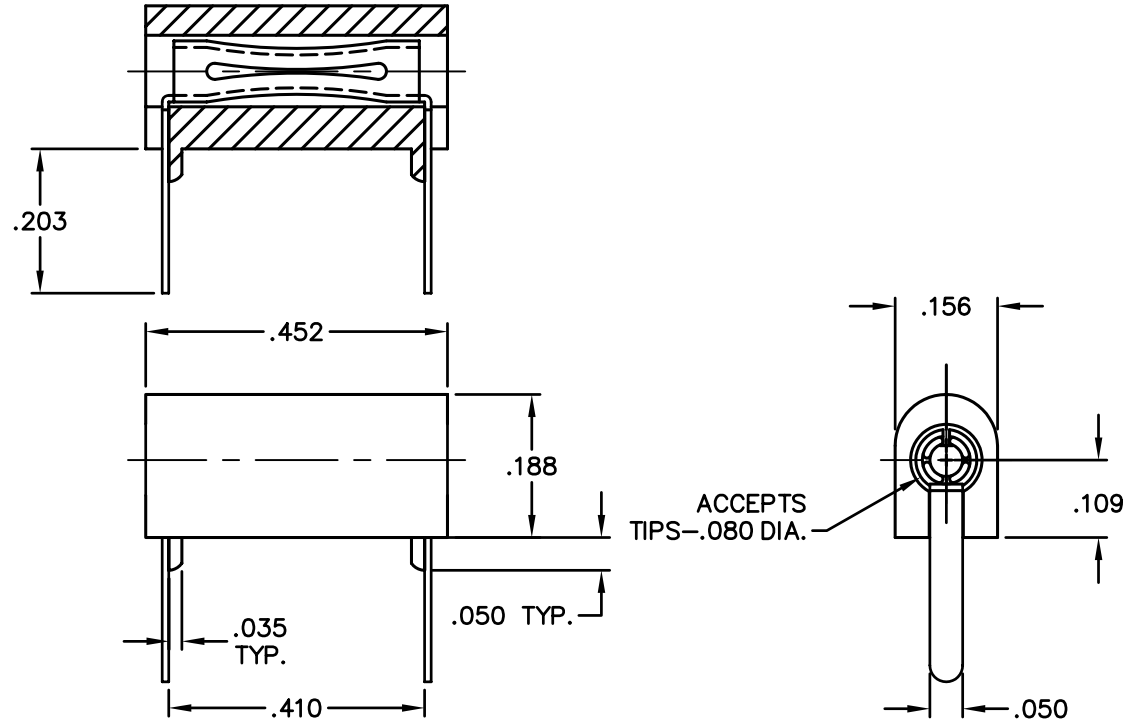

DET	QTY	DESC	MATERIAL	FINISH
1	1	HOUSING	NYLON	NA
2	1	CONTACT	BeCu	GOLD

MATERIAL: SEE TABLE		FINISH: SEE TABLE		<h1>ABBATRON</h1> <p>Electronic Connectors and Hardware 632 Arch Street, Meadville, Pa. 16335</p>		
DIMENSIONAL TOLERANCES UNLESS OTHERWISE SPECIFIED		TITLE: 430				SIZE: B DRAWING NUMBER: SD-430 ISSUE: B
.XX	.XXX	.XXX	TEST JACK ASSEMBLY			
---	---	---				
FRACTIONS	ANGLES	SCALE	DRAWN: T. LORD DATE: 4/28/03			
---	---	5X	CHECKED: T. LORD DATE: 4/28/03			
HEAT TREAT: ---		APPROVED: T. LORD DATE: 4/28/03				
PLOT SCALE: 1=1						