

BILL OF MATERIALS				
DET.	QTY.	DESCRIPTION	MATERIAL	PLATING
1	1	SPRING	BE CU	NICKEL
2	1	HEX NUT	STEEL	ZINC
3	1	LUG	.010 BRASS	TIN
4	1	BODY	BRASS	NICKEL

REVISIONS				
SYM	DESCRIPTION	REVISED BY	DATE	APPR

FULL SECTION

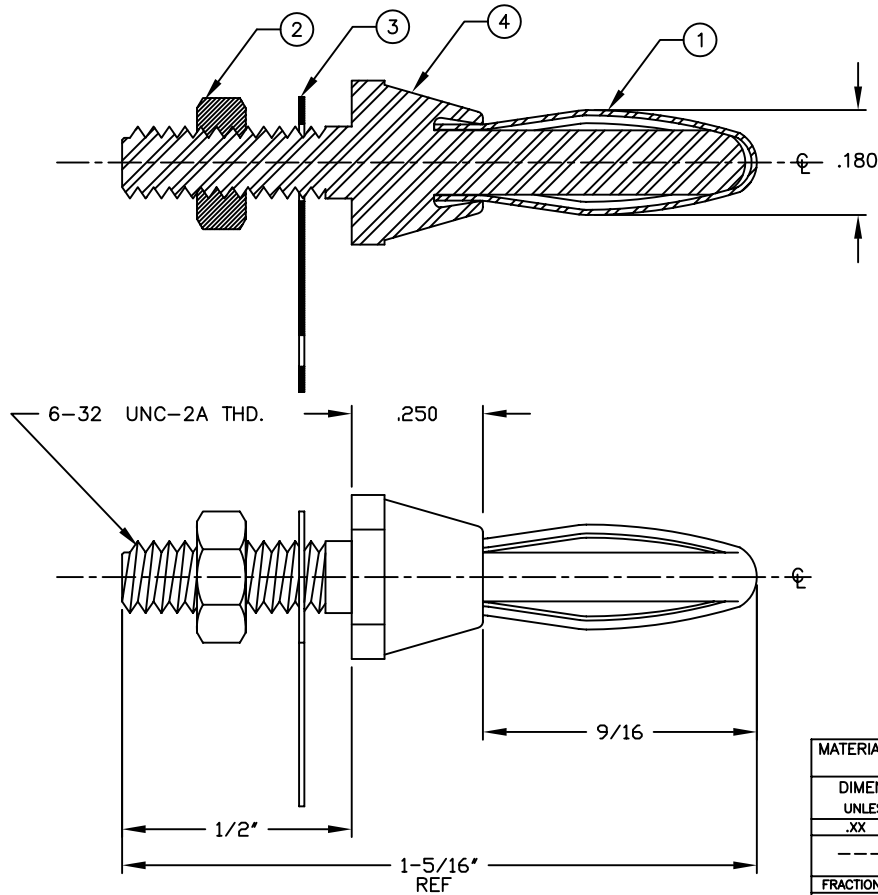

NOTE 1: BODY AND SPRING TO BE ASSEMBLED BEFORE PLATE

MATERIAL: "SEE TABLE"			FINISH: "SEE TABLE"			ABBATRON Electronic Connectors and Hardware 632 Arch Street, Meadville, Pa. 16335					
DIMENSIONAL TOLERANCES UNLESS OTHERWISE SPECIFIED			TITLE: 423						SIZE DRAWING NUMBER ISSUE B SD-432 C		
.XX	.XXX	.XXXX	BANANA PLUG ASSEMBLY								
---	---	---	DRAWN: S. GERHOLD DATE: 7-27-95								
FRACTIONS	ANGLES	SCALE	CHECKED: E. MCKINNEY DATE: 8-1-95								
---	---	4:1	APPROVED: M. KLOECKER DATE: 8-3-95								
HEAT TREAT: ---			PLOT SCALE: 1=1								