

BILL OF MATERIALS

DET.	QTY.	DESCRIPTION	MATERIAL	PLATING
1	1	INSUL-HV TOP	STEATITE	WHITE GLAZE
2	1	INSUL-HV BOTTOM	STEATITE	WHITE GLAZE
3	1	#6-32 STUD	BRASS	NICKEL
4	2	INSULATING WASHER	CHAM PAC	-
5	2	WASHER	BRASS	NICKEL
6	4	HEX NUT	BRASS	NICKEL

REVISIONS

SYM	DESCRIPTION	REVISED BY	DATE	APPR

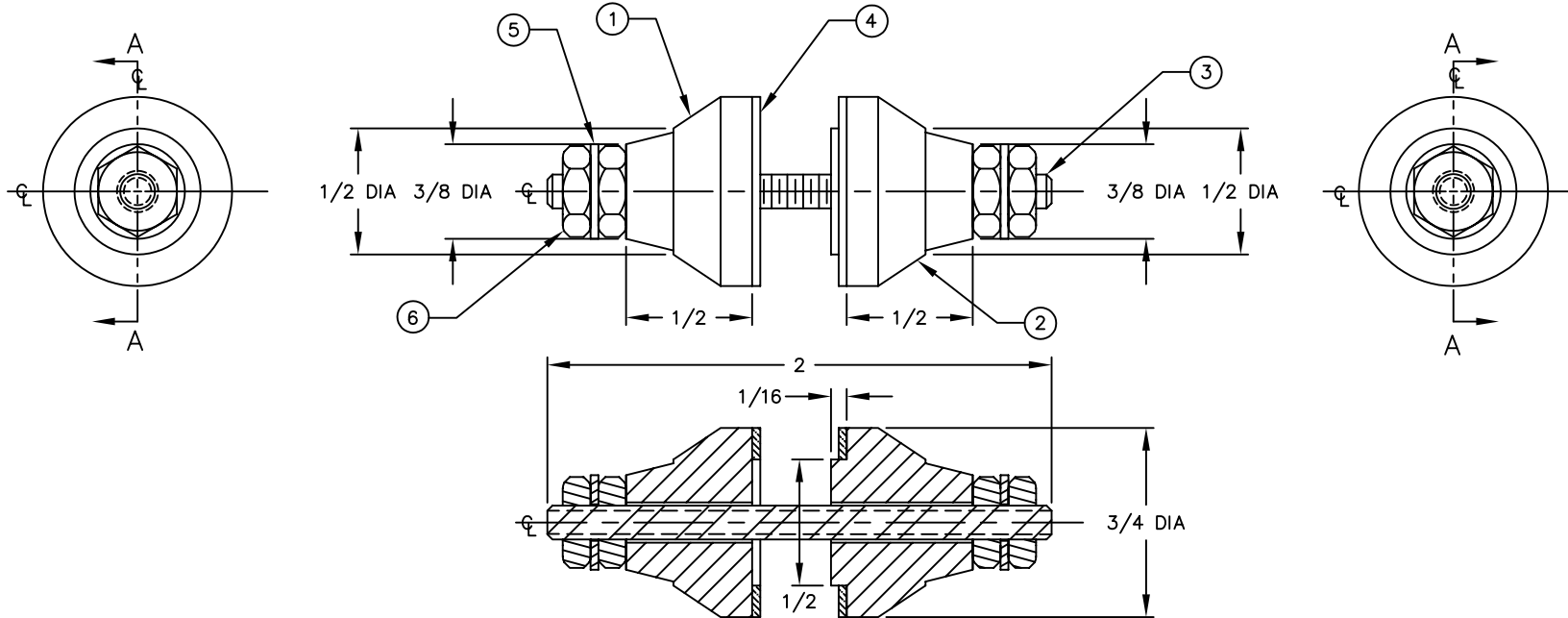

SECTION A-A

MATERIAL: SEE TABLE			FINISH: ---			<h1>ABBATRON</h1> <p>Electronic Connectors and Hardware 632 Arch Street, Meadville, Pa. 16335</p>					
DIMENSIONAL TOLERANCES UNLESS OTHERWISE SPECIFIED			TITLE: 9550AA						SIZE: B DRAWING NUMBER: SD-9550AA ISSUE: A		
.XX	.XXX	.XXXX	HIGH VOLTAGE INSULATOR								
---	---	---	REF. 5204								
FRACTIONS	ANGLES	SCALE	DRAWN: JOEL FALVEY DATE: 3-18-97			CHECKED: _____ DATE: _____					
---	---	2:1	HEAT TREAT: ---			APPROVED: _____ DATE: _____					
PLOT SCALE: 1=1											